



# PRODUCT/PROCESS CHANGE NOTIFICATION

---

PCN AMS-AAS/14/8379  
Dated 11 Mar 2014

---

**New material set in Shenzhen plant for Power switch  
products in SO8 package**

**Table 1. Change Implementation Schedule**

Forecasted implementation date for change	04-Mar-2014
Forecasted availability date of samples for customer	04-Mar-2014
Forecasted date for <b>STMicroelectronics</b> change Qualification Plan results availability	04-Mar-2014
Estimated date of changed product first shipment	10-Jun-2014

**Table 2. Change Identification**

Product Identification (Product Family/Commercial Product)	Power switch products
Type of change	Package assembly material change
Reason for change	To be more consistent with current assembly fabrication practices
Description of the change	Progressing on the activities related to SO8 package in ST Shenzhen, ST is glad to announce a new material set for Power switch products. The molding compound, the die attach glue and the leadframe material will be changed to be more consistent with the current assembly practices.
Change Product Identification	"G" letter in traceability code on the package
Manufacturing Location(s)	

**Table 3. List of Attachments**

Customer Part numbers list	
Qualification Plan results	

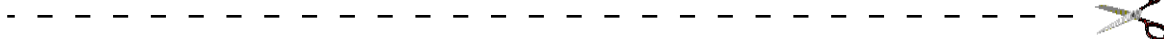

Customer Acknowledgement of Receipt		PCN AMS-AAS/14/8379					
Please sign and return to STMicroelectronics Sales Office		Dated 11 Mar 2014					
<input type="checkbox"/> Qualification Plan Denied <input type="checkbox"/> Qualification Plan Approved  <input type="checkbox"/> Change Denied <input type="checkbox"/> Change Approved	<table border="1" style="width: 100%; border-collapse: collapse;"> <tr><td style="padding: 2px;">Name:</td></tr> <tr><td style="padding: 2px;">Title:</td></tr> <tr><td style="padding: 2px;">Company:</td></tr> <tr><td style="padding: 2px;">Date:</td></tr> <tr><td style="padding: 2px;">Signature:</td></tr> </table>		Name:	Title:	Company:	Date:	Signature:
Name:							
Title:							
Company:							
Date:							
Signature:							
Remark ..... ..... ..... ..... ..... ..... ..... ..... ..... .....							

## DOCUMENT APPROVAL

Name	Function
Grillo, Lionel	Marketing Manager
Onetti, Andrea Mario	Product Manager
Bugnard, Jean-Marc	Q.A. Manager

***Analog, MEMS and Sensors Group - AMS***  
***Analog and Audio Systems Division (AAS)***

**New material set in Shenzhen plant for Power switch products  
in SO8 package**

**WHAT:**

Progressing on the activities related to SO8 package in ST Shenzhen, ST is glad to announce a new material set for Power switch products.

Please find more information in the table here below.

Material	Current process	Modified process	Comment
Diffusion location	ST Ang Mo Kio (Singapore)	ST Ang Mo Kio (Singapore)	No change
Assembly location	ST Shenzhen	ST Shenzhen	No change
Molding compound	Nitto MP8000	Sumitomo G700K	Lower stress molding compound bringing major improvement for package robustness versus customer soldering stress. Less delamination risk.
Die attach	Hitachi 4900ST10	Ablestick 8601-S25	New glue will solve sporadic glue homogeneity issue we could encounter in past years.
Leadframe	Copper preplated NiPdAu	Copper preplated NiPdAgAu	Ag layer bring higher roughness which allow better adhesion on frame and better solderability of the wire.
Wire	Gold 1.3mils	Gold 1.3mils	No change

For the complete list of affected part numbers, please refer to the attached Product list. Samples of vehicle test are available now and other samples will be launched upon customer's request. Please submit requests for samples within 30 days of this notification.

**WHY:**

This change will ensure a higher quality level for Power switch products processed in BCD6S process.

Please note that this PCN is replacing the PCN APM/11/6872 sent in 2011 and announcing the introduction of copper wire. The PCN APM/11/6872 has been cancelled due to production constraints.

**HOW:**

The qualification program consists mainly of comparative electrical characterization and reliability tests.

You will find here after the qualification test plan which summarizes the various test methods and conditions that ST uses for this qualification program.

**WHEN:**

The new material set production in ST Shenzhen for Power switch products will be introduced by Q1/Q2'2014.

**Marking and traceability:**

Unless otherwise stated by customer's specific requirement, the traceability of the parts assembled with the new material set will be ensured by date code and lot number.

The changes here reported will not affect the electrical, dimensional and thermal parameters keeping unchanged all the information reported on the relevant datasheets.

There is -as well- no change in the packing process or in the standard delivery quantities.

Lack of acknowledgement of the PCN within 30 days will constitute acceptance of the change. After acknowledgement, lack of additional response within the 90 day period will constitute acceptance of the change (Jedec Standard No. 46-C).

Shipments may start earlier with the customer's written agreement.

## Qualification Report

*Qualification of a new material set for SO8 package in Shenzhen for AAS Division*

General Information	
<b>Product Line</b>	<i>UM3701</i>
<b>Product Description</b>	<i>Enhanced single channel power switches</i>
<b>P/N</b>	<i>STMPS2141MTR</i>
<b>Product Group</b>	<i>AMS</i>
<b>Product division</b>	<i>AAS</i>
<b>Package</b>	<i>SO8</i>
<b>Silicon Process technology</b>	<i>BCD6</i>
<b>Production mask set rev.</b>	<i>1</i>
<b>Maturity level step</b>	<i>from 20 to 30</i>

Locations	
<b>Wafer fab</b>	<i>ST CATANIA - ITALY</i>
<b>Assembly plant</b>	<i>ST SHENZHEN - CHINA</i>
<b>Reliability Lab</b>	<i>ST SHENZHEN - CHINA</i>
<b>Reliability assessment</b>	<i>Done</i>

### DOCUMENT INFORMATION

Version	Date	Pages	Prepared by	Comment
1.0	22-Jan-2014		JM Bugnard	First issue

**Reference:** Report ID 2014-W404 SO8 SHD SZH (Sandra Fassetta 22<sup>nd</sup> Jan 2014)

Note: This report is a summary of the reliability trials performed in good faith by STMicroelectronics in order to evaluate the potential reliability risks during the product life using a set of defined test methods.  
 This report does not imply for STMicroelectronics expressly or implicitly any contractual obligations other than as set forth in STMicroelectronics general terms and conditions of Sale. This report and its contents shall not be disclosed to a third party without previous written agreement from STMicroelectronics.



## TABLE OF CONTENTS

<b>1</b>	<b>APPLICABLE AND REFERENCE DOCUMENTS .....</b>	<b>6</b>
<b>2</b>	<b>GLOSSARY.....</b>	<b>6</b>
<b>3</b>	<b>RELIABILITY EVALUATION OVERVIEW.....</b>	<b>6</b>
3.1	OBJECTIVES .....	6
3.2	CONCLUSION .....	6
<b>4</b>	<b>DEVICE CHARACTERISTICS.....</b>	<b>7</b>
4.1	DEVICE DESCRIPTION.....	7
4.2	CONSTRUCTION NOTE .....	8
<b>5</b>	<b>TESTS RESULTS SUMMARY.....</b>	<b>9</b>
5.1	TEST VEHICLE.....	9
5.2	TEST PLAN AND RESULTS SUMMARY.....	9
<b>6</b>	<b>ANNEXES.....</b>	<b>10</b>
6.1	DEVICE DETAILS.....	10
6.2	TESTS DESCRIPTION.....	13
6.3	WIRE PULL AND BALL SHEAR RESULTS.....	14
6.4	FINAL TESTING ROOM TEMPERATURE.....	15

## **1 APPLICABLE AND REFERENCE DOCUMENTS**

<b>Document reference</b>	<b>Short description</b>
<b>AEC-Q100</b>	Stress test qualification for automotive grade integrated circuits
<b>AEC-Q101</b>	Stress test qualification for automotive grade discrete semiconductors
<b>JESD47</b>	Stress-Test-Driven Qualification of Integrated Circuits

## **2 GLOSSARY**

<b>DUT</b>	Device Under Test
<b>PCB</b>	Printed Circuit Board
<b>SS</b>	Sample Size

## **3 RELIABILITY EVALUATION OVERVIEW**

### **3.1 Objectives**

The objective of this qualification is to qualify the new material set for power switch products produced in SO8 in ST Shenzhen with BCD6 technology.

The qualification plan is based on the similarity and based on the JESD47 specification.

### **3.2 Conclusion**

Qualification Plan requirements have been fulfilled without exception. The reliability tests show that the device is behaving correctly against environmental tests (no failure). Moreover, the stability of electrical parameters during the accelerated tests demonstrates the ruggedness of the products and safe operation, which is consequently expected during their lifetime.

Reliability agreement for the maturity 30 level is done for this qualification.

## 4 DEVICE CHARACTERISTICS

### 4.1 Device description



## STMPS2141, STMPS2151, STMPS2161, STMPS2171

Enhanced single channel power switches

Datasheet – production data

#### Features

- 90 mΩ high-side MOSFET switch
- 500/1000 mA continuous current
- Thermal and short-circuit protection with overcurrent logic output
- Operating range from 2.7 to 5.5 V
- CMOS and TTL compatible enable input
- Undervoltage lockout (UVLO)
- 12 μA maximum standby supply current
- Ambient temperature range, -40 to 85 °C
- 8 kV ESD protection
- Reverse current protection
- Fault blanking
- UL recognized components (UL file number: E354278)

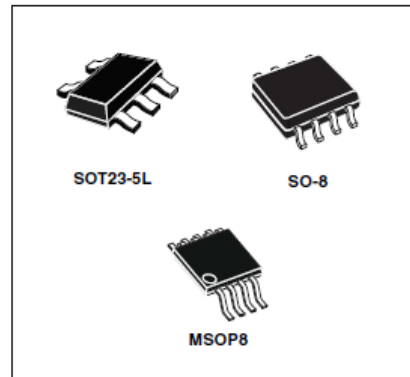

#### Description

The STMPS2141, STMPS2151, STMPS2161, STMPS2171 power distribution switches are intended for applications where heavy capacitive loads and short-circuits are likely to be encountered. These devices incorporate 90 mΩ N-channel MOSFET high-side power switches for power distribution. These switches are controlled by a logic enable input.

When the output load exceeds the current limit threshold or a short is present, the device limits the output current to a safe level by switching into a constant current mode. When continuous heavy overloads and short-circuits increase the power dissipation in the switch, causing the junction temperature to rise, a thermal protection circuit shuts the switch off to prevent damage. Recovery from a thermal shutdown is automatic once the device has cooled sufficiently. Internal circuitry ensures the switch remains off until a valid input voltage is present.

Table 1. Device summary

Order codes			Rated continuous output current (mA)	Enable
SO-8	SOT23-5L	MSOP8 <sup>(1)</sup>		
STMPS2141MTR	STMPS2141STR	STMPS2141TTR	500	Active low
STMPS2151MTR	STMPS2151STR	STMPS2151TTR	500	Active high
STMPS2161MTR	STMPS2161STR	STMPS2161TTR	1000	Active low
STMPS2171MTR	STMPS2171STR	STMPS2171TTR	1000	Active high

1. MSOP8 package is also known as "TSSOP8".

## 4.2 Construction note

	P/N STMPS2141MTR	P/N: ST1S31	P/N L4931ABxx
<b>Wafer/Die fab. information</b>			
Wafer fab manufacturing location	ST CATANIA - ITALY	ST CATANIA - ITALY	ST Ang Mo Kio
Technology	BCD	BCD	Bipolar
Process family	BCD6	BCD6	Bipolar >6µm
Die finishing back side	Raw Silicon	Cr/NiV/Au	Cr/NiV/Au
Die size	2098 x 598 µm	1886x1541 µm	1770x1850 UM
Bond pad metallization layers	Ti/AICu/TiNARC	Ti/AICu/TiNARC	AlSiCu
Passivation type	TEOS/SiN/Polyimide	TEOS/SiN/Polyimide	SiN
<b>Assembly information</b>			
Assembly site	ST SHENZHEN - CHINA	ST SHENZHEN - CHINA	ST SHENZHEN - CHINA
Package description	SO8	SO8	SO8
Molding compound	SUMITOMO EME-G700K	SUMITOMO EME-G700K	SUMITOMO EME-G700K
Frame material	Cu	Cu	Cu
Die attach process	Glue	Glue	Glue
Die attach material	ABLEBOND 8601S	ABLEBOND 8601S	ABLEBOND 8601S
Die pad size	280 x 81 µm	90x90 90x200	90x90 90x200
Wire bonding process	Wire	Wire	Wire
Wires bonding materials/diameters	Gold 1.3 mils	Gold 1.3 mils	Gold 1.3 mils
Lead finishing process	preplated	preplated	preplated
Lead finishing/bump solder material	NiThPdAgAu	NiThPdAu	NiThPdAu
<b>Final testing information</b>			
Testing location	ST SHENZHEN - CHINA	ST SHENZHEN - CHINA	ST SHENZHEN - CHINA
Tester	ASL1000	ASL1000	QT200
Test program	UM37J54SF	UA17	LW2SFH50.CTS



## 5 TESTS RESULTS SUMMARY

### 5.1 Test vehicle

Lot #	Assy Lot	Process/Package	Product Line	Comments
1	GK3240NQ01	SO8	UM3701	RL: IKO7*UM37J54
2	GK1500kQ01	SO8	UA17	RL: MZO7*UA17AA8
3	GK1121DS GK1041Y2 GK1041Y2	SO8	LW05	

Detailed results in below chapter will refer to P/N and Lot #.

### 5.2 Test plan and results summary

P/N STMPS2141MTR

Test	PC	Std ref.	Conditions	SS	Steps	Failure/SS			Note
						Lot 1	Lot 2	Lot 3	
<b>Package Oriented Tests</b>									
MSL			Bake 125°C @24hrs+85°C / 85%RH @168hrs+reflow 260°C @3times		Final	Pass	Pass	Pass	
AC	Y	JESD22 A-102	Pa=2Atm / Ta=121°C		96 H 168 H	0/78 0/78	0/77 0/77	0/77 0/77	
TC	Y	JESD22 A-104	Ta = -65°C to 150°C		100 cy 500 cy	0/78 0/78	0/77 0/77	0/77 0/77	
THB	Y	JESD22 A-101	Ta = 85°C, RH = 85%, BIAS=7V		1000h		0/77		
<b>Other Tests</b>									
FINAL TESTING room temperature				100		Pass	--	--	
SD (Solderability)	N	AEC Q100	Steam 8hrs, flux dwell 5s to 10s. SnAgCu Temperature 245+/-3 degree	50		Pass		--	
PD (Physical dimension)	N	AEC Q100		5		Pass	--	--	
BPS (Bond Pull Strength)	N	MIL – STD683	30 Wires pull shear	5	30 bonds / 5 devices	Pass	--	--	
BS (Bond shear strength)	N	AECQ100	30 Wires ball shear	5	30 bonds / 5 devices	Pass	--	--	

## 6 ANNEXES

### 6.1 Device details

#### 6.1.1 Pin connection

##### Pin connections

Figure 2. SOT23-5L, SO-8 and MSOP8 pin connections

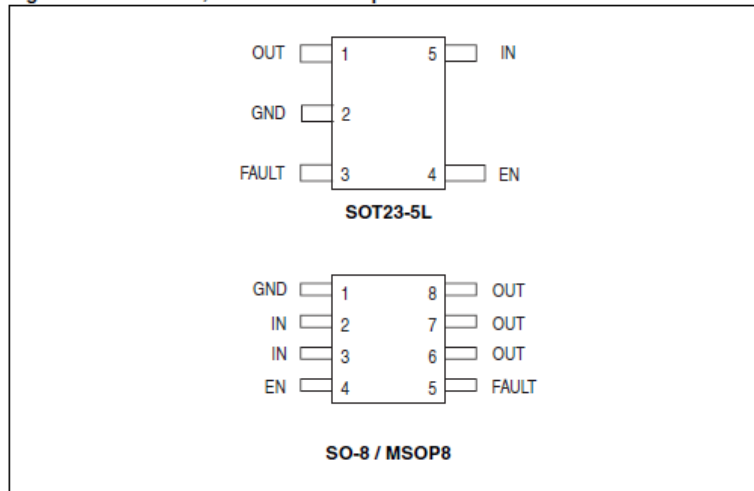

##### Pin description

Table 2. Pin description

Pin number			Name	Function
SO-8	MSOP8	SOT23-5L		
1	1	2	GND	Ground
2	2	5	IN	2.7 - 5.5 V input
3	3	-	IN	2.7 - 5.5 V input
4	4	4	EN	Enable for power switch
5	5	3	FAULT	Open drain FAULT indicator, active low
6	6	1	OUT	Output of power switch
7	7	-	OUT	Output of power switch
8	8	-	OUT	Output of power switch

### 6.1.2 Bonding diagram

TITLE: MOUNT BOND DIAGRAM FOR LINE UM37 S08 3068

FRAME PAD:  $\frac{94 \times 125 \text{ Mils}}{2.38 \times 3.17 \text{ mm}}$     MAX DIE SIZE:  $\frac{84 \times 115 \text{ Mils}}{2.13 \times 2.92 \text{ mm}}$

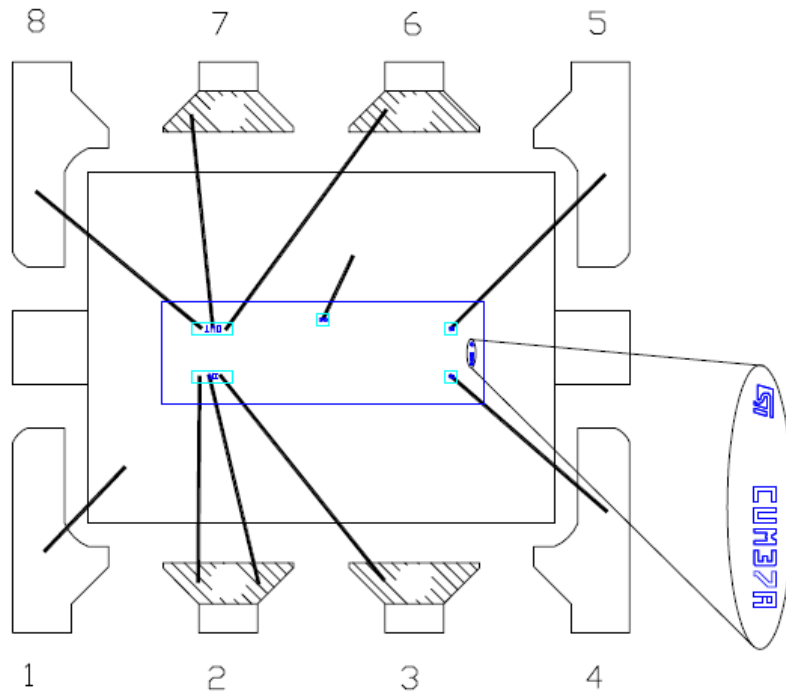

SCALE :  $\frac{1 \text{ mm}}{\text{---}}$

Pin 1



NOTE: E.S.D. PROGRAM IS MANDATORY

### 6.1.3 Package outline/Mechanical data

**TITLE: PLASTIC SMALL OUTLINE PACKAGE 8L**

**PACKAGE CODE: O7 (O like OSCAR)**

**PACKAGE WEIGHT: 0,0765 g/unit typ**

**JEDEC/EIAJ REFERENCE NUMBER: JEDEC MS-012-AA**

DIMENSIONS							
REF.	DATABOOK (mm)			DRAWING (mm)			NOTES
	MIN.	TYP.	MAX.	MIN.	TYP.	MAX.	
A			1.75			1.74	
A1	0.10		0.25	0.12	0.15	0.18	
A2	1.25			1.48	1.52	1.56	
b	0.28		0.48	0.375	0.40	0.425	
c	0.17		0.23	0.192	0.20	0.225	
D	4.80	4.90	5.00	4.87	4.90	4.93	(1)
E	5.80	6.00	6.20	5.90	6.00	6.10	
E1	3.80	3.90	4.00	3.87	3.90	3.93	(2)
e		1.27			1.27		
h	0.25		0.50	0.425		0.50	
L	0.40		1.27	SEE LEADFRAME OPTIONS			
L1		1.04			1.05		
k	0		8	2	4	8	DEGREES
ccc			0.10			0.04	

LEADFRAME OPTIONS							
REF.	PREPLATED			POSTPLATED			NOTES
	MIN.	TYP.	MAX.	MIN.	TYP.	MAX.	
L	0.567	0.617	0.667	0.585	0.635	0.685	

**NOTES:**



- (1) – Dimension "D" does not include mold flash, protrusions or gate burrs.  
Mold flash, protrusions or gate burrs shall not exceed 0.15mm in total (both side).
- (2) – Dimension "E1" does not include interlead flash or protrusions.  
Interlead flash or protrusions shall not exceed 0.25mm per side.



## 6.2 Tests Description

Test name	Description	Purpose
<b>Die Oriented</b>		
<b>HTOL</b> High Temperature Operating Life  <b>HTB</b> High Temperature Bias	The device is stressed in static or dynamic configuration, approaching the operative max. absolute ratings in terms of junction temperature and bias condition.	To determine the effects of bias conditions and temperature on solid state devices over time. It simulates the devices' operating condition in an accelerated way. The typical failure modes are related to, silicon degradation, wire-bonds degradation, oxide faults.
<b>HTSL</b> High Temperature Storage Life	The device is stored in unbiased condition at the max. temperature allowed by the package materials, sometimes higher than the max. operative temperature.	To investigate the failure mechanisms activated by high temperature, typically wire-bonds solder joint ageing, data retention faults, metal stress-voiding.
<b>ELFR</b> Early Life Failure Rate	The device is stressed in biased conditions at the max junction temperature.	To evaluate the defects inducing failure in early life.
<b>Package Oriented</b>		
<b>PC</b> Preconditioning	The device is submitted to a typical temperature profile used for surface mounting devices, after a controlled moisture absorption.	As stand-alone test: to investigate the moisture sensitivity level. As preconditioning before other reliability tests: to verify that the surface mounting stress does not impact on the subsequent reliability performance. The typical failure modes are "pop corn" effect and delamination.
<b>AC</b> Auto Clave (Pressure Pot)	The device is stored in saturated steam, at fixed and controlled conditions of pressure and temperature.	To investigate corrosion phenomena affecting die or package materials, related to chemical contamination and package hermeticity.
<b>TC</b> Temperature Cycling	The device is submitted to cycled temperature excursions, between a hot and a cold chamber in air atmosphere.	To investigate failure modes related to the thermo-mechanical stress induced by the different thermal expansion of the materials interacting in the die-package system. Typical failure modes are linked to metal displacement, dielectric cracking, molding compound delamination, wire-bonds failure, die-attach layer degradation.
<b>THB</b> Temperature Humidity Bias	The device is biased in static configuration minimizing its internal power dissipation, and stored at controlled conditions of ambient temperature and relative humidity.	To evaluate the package moisture resistance with electrical field applied, both electrolytic and galvanic corrosion are put in evidence.
<b>Other</b>		
<b>ESD</b> Electro Static Discharge	The device is submitted to a high voltage peak on all his pins simulating ESD stress according to different simulation models. <b>CBM:</b> Charged Device Model <b>HBM:</b> Human Body Model <b>MM:</b> Machine Model	To classify the device according to his susceptibility to damage or degradation by exposure to electrostatic discharge.
<b>LU</b> Latch-Up	The device is submitted to a direct current forced/sunk into the input/output pins. Removing the direct current no change in the supply current must be observed.	To verify the presence of bulk parasitic effect inducing latch-up.

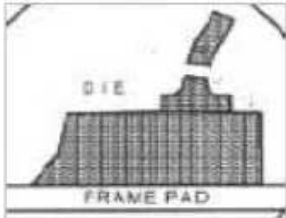
### 6.3 Wire Pull and Ball Shear Results

No	Wire pull spec:6g			Ball shear spec:21.2g			
1	17.21	16	17.54	1	48.43	16	63.16
2	17	17	17.2	2	49.53	17	61.03
3	16.38	18	17.88	3	43.8	18	64.39
4	16.73	19	17.67	4	47.68	19	52.24
5	17.62	20	16.7	5	49.94	20	50.06
6	16.6	21	16.34	6	46.16	21	48.61
7	17.26	22	17.43	7	53.17	22	49.27
8	17.35	23	17.41	8	59.61	23	61.03
9	18.22	24	16.7	9	53.89	24	64.39
10	17.64	25	17.04	10	55.93	25	52.24
11	18.23	26	17.85	11	58.21	26	48.06
12	17.15	27	17.96	12	64.7	27	48.61
13	17.74	28	19.31	13	52.33	28	49.27
14	17.56	29	16.93	14	63.41	29	48.61
15	16.97	30	17.69	15	55.16	30	49.57
Avg	17.377			53.749			
3*STDEV	1.868			18.801			
CPK	6.087			1.731			
Failure mode	 <p>Ball neck breck</p>			 <p>Ball shear</p>			

**Conclusion: WP/BS result within spec and CPK>1.67.**

## **6.4 FINAL TESTING room temperature**

Comparison data: lot new version GK3430YL01, lot previous version GK24417A02

Parameter	New material set Cpk	previous material set Cpk
InPin versus GND	74.37	90.17
En pin	83.03	106.31
OC pin	83.99	104.45
Out pin	81.59	102.38
RdSon	28.63	20.78
Vp	4.27	4.16
VN	4.31	4.12
Current In-IOFF	8.09	7.54
Current IN-ION	3.50	3.73
Current IN-IOFF	8.17	7.61

**Please Read Carefully:**

Information in this document is provided solely in connection with ST products. STMicroelectronics NV and its subsidiaries ("ST") reserve the right to make changes, corrections, modifications or improvements, to this document, and the products and services described herein at any time, without notice.

All ST products are sold pursuant to ST's terms and conditions of sale.

Purchasers are solely responsible for the choice, selection and use of the ST products and services described herein, and ST assumes no liability whatsoever relating to the choice, selection or use of the ST products and services described herein.

No license, express or implied, by estoppel or otherwise, to any intellectual property rights is granted under this document. If any part of this document refers to any third party products or services it shall not be deemed a license grant by ST for the use of such third party products or services, or any intellectual property contained therein or considered as a warranty covering the use in any manner whatsoever of such third party products or services or any intellectual property contained therein.

**UNLESS OTHERWISE SET FORTH IN ST'S TERMS AND CONDITIONS OF SALE ST DISCLAIMS ANY EXPRESS OR IMPLIED WARRANTY WITH RESPECT TO THE USE AND/OR SALE OF ST PRODUCTS INCLUDING WITHOUT LIMITATION IMPLIED WARRANTIES OF MERCHANTABILITY, FITNESS FOR A PARTICULAR PURPOSE ( AND THEIR EQUIVALENTS UNDER THE LAWS OF ANY JURISDICTION ), OR INFRINGEMENT OF ANY PATENT, COPYRIGHT OR OTHER INTELLECTUAL PROPERTY RIGHT.**

**ST PRODUCTS ARE NOT DESIGNED OR AUTHORIZED FOR USE IN: (A) SAFETY CRITICAL APPLICATIONS SUCH AS LIFE SUPPORTING, ACTIVE IMPLANTED DEVICES OR SYSTEMS WITH PRODUCT FUNCTIONAL SAFETY REQUIREMENTS; (B) AERONAUTIC APPLICATIONS; (C) AUTOMOTIVE APPLICATIONS OR ENVIRONMENTS, AND/OR (D) AEROSPACE APPLICATIONS OR ENVIRONMENTS. WHERE ST PRODUCTS ARE NOT DESIGNED FOR SUCH USE, THE PURCHASER SHALL USE PRODUCTS AT PURCHASER'S SOLE RISK, EVEN IF ST HAS BEEN INFORMED IN WRITING OF SUCH USAGE, UNLESS A PRODUCT IS EXPRESSLY DESIGNATED BY ST AS BEING INTENDED FOR "AUTOMOTIVE, AUTOMOTIVE SAFETY OR MEDICAL" INDUSTRY DOMAINS ACCORDING TO ST PRODUCT DESIGN SPECIFICATIONS. PRODUCTS FORMALLY ESCC, QML OR JAN QUALIFIED ARE DEEMED SUITABLE FOR USE IN AEROSPACE BY THE CORRESPONDING GOVERNMENTAL AGENCY.**

**RESTRICTIONS OF USE AND CONFIDENTIALITY OBLIGATIONS:**

**THIS DOCUMENT AND ITS ANNEXES CONTAIN ST PROPRIETARY AND CONFIDENTIAL INFORMATION. THE DISCLOSURE, DISTRIBUTION, PUBLICATION OF WHATSOEVER NATURE OR USE FOR ANY OTHER PURPOSE THAN PROVIDED IN THIS DOCUMENT OF ANY INFORMATION CONTAINED IN THIS DOCUMENT AND ITS ANNEXES IS SUBMITTED TO ST PRIOR EXPRESS AUTHORIZATION. ANY UNAUTHORIZED REVIEW, USE, DISCLOSURE OR DISTRIBUTION OF SUCH INFORMATION IS EXPRESSLY PROHIBITED.**

Resale of ST products with provisions different from the statements and/or technical features set forth in this document shall immediately void any warranty granted by ST for the ST product or service described herein and shall not create or extend in any manner whatsoever, any liability of ST.

ST and the ST logo are trademarks or registered trademarks of ST in various countries.

Information in this document supersedes and replaces all information previously supplied.

The ST logo is a registered trademark of STMicroelectronics. All other names are the property of their respective owners

©2014 STMicroelectronics - All rights reserved.

STMicroelectronics group of companies

Australia - Belgium - Brazil - Canada - China - Czech Republic - Finland - France - Germany - Hong Kong - India - Israel - Italy - Japan - Malaysia - Malta - Morocco - Philippines - Singapore - Spain - Sweden - Switzerland - United Kingdom - United States of America

[www.st.com](http://www.st.com)

